

GENERAL TOLERANCE										USED ON
10 MAX	30 MAX	50 MAX	70 MAX	100 MAX	120 MAX	250 MAX	250 OVER	ANGLE	ECCENT	
±0.15	±0.20	±0.30	±0.40	±0.50	±0.75	±0.90	±1.4	±0.5°	0.1	

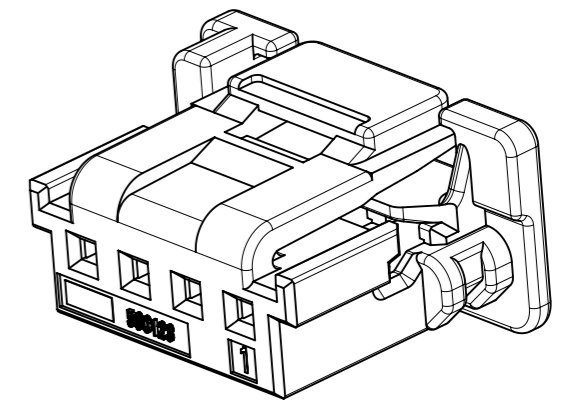

ISO VIEW

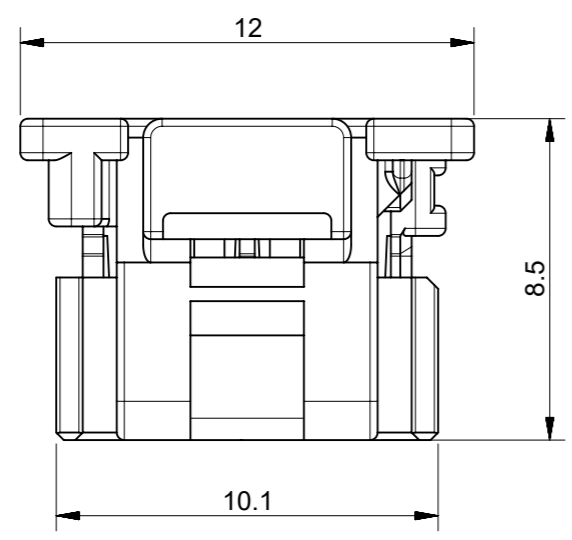
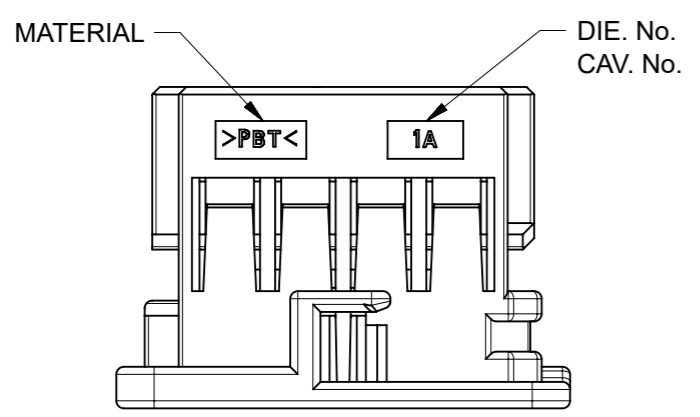
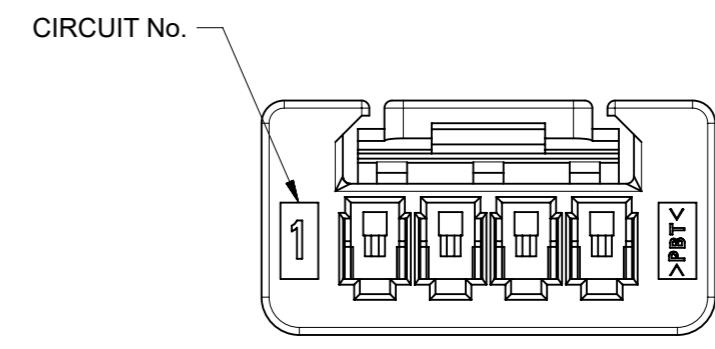
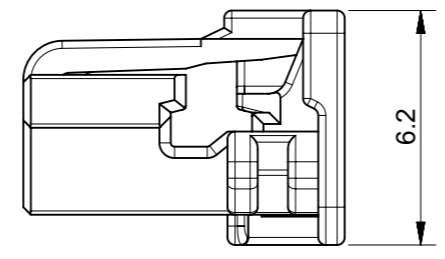
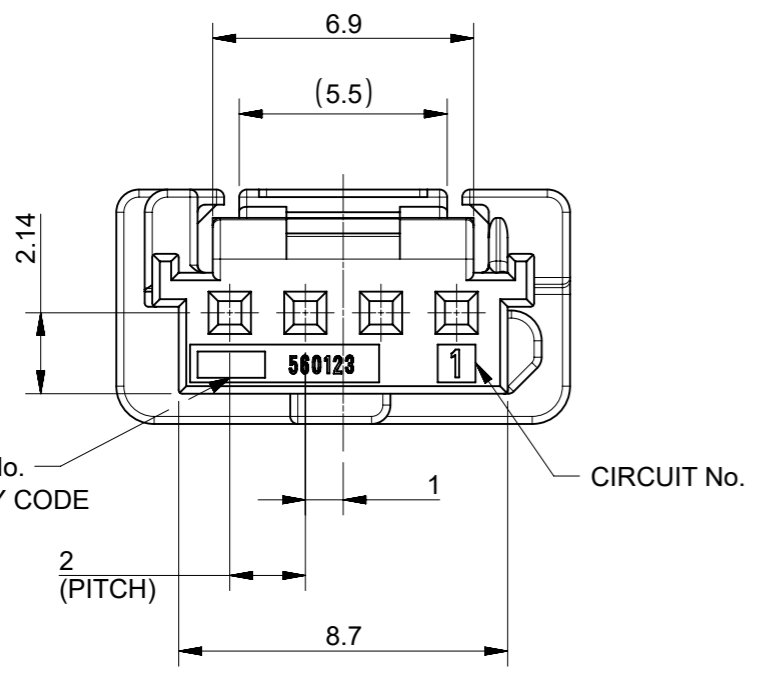

PENDING APPROVAL

- NOTES:
1. MATERIALS : POLYESTER (PBT), GLASS UNFILLED, UL 94V-0
 2. MATE WITH : 502352, 560020 SERIES
 3. APPLICABLE TERMINAL : 560124 SERIES
 4. APPLICABLE ISL : 560125 SERIES
 5. GENERAL TOLERANCE : SEE TABLE
 6. EVL AND RoHS COMPLIANT
 7. PRODUCT SPECIFICATION : PS-560123-001,002,003
 8. PACKING SPECIFICATION : PK-560123-001

ORDER NO.	MATERIAL NO.	COLOR
560123-0400	5601230400	WHITE
560123-0401	5601230401	BLACK
560123-0402	5601230402	RED
560123-0404	5601230404	BLUE

SYMBOLS		THIS DRAWING CONTAINS INFORMATION THAT IS PROPRIETARY TO MOLEX ELECTRONIC TECHNOLOGIES, LLC AND SHOULD NOT BE USED WITHOUT WRITTEN PERMISSION		CURRENT REV DESC:	
▽ = 0	mm	SCALE	5:1	EC NO: 629104	
▽ = 0	GENERAL TOLERANCES (UNLESS SPECIFIED)			DRWN: SAKIM	2019/12/11
▽ = 0	ANGULAR TOL ± °			CHK'D:	
▽ = 0	4 PLACES	±		APPR:	
▽ = 0	3 PLACES	±		INITIAL REVISION:	
▽ = 0	2 PLACES	±		DRWN: YIBAEK	2014/07/03
▽ = 0	1 PLACE	±		APPR: SRTAK	2014/08/26
▽ = 0	0 PLACES	±		THIRD ANGLE PROJECTION	
▽ = 0	DRAFT WHERE APPLICABLE MUST REMAIN WITHIN DIMENSIONS			DRAWING	SERIES
				A3-SIZE	560123
DOCUMENT STATUS		RQ	RELEASE DATE	DOCUMENT NUMBER	
				SD-560123-002	
				DOC TYPE	DOC PART
				PSD	001
				REVISION	C1
				MATERIAL NUMBER	
				GENERAL MARKET	
				CUSTOMER	
				SHEET NUMBER	
				1 OF 1	

DOCUMENT STATUS	RQ	RELEASE DATE
-----------------	----	--------------